

TRITON[®]

SONIC WIND PROFILER

The Wind Industry's Leading Remote Sensing System



 **SECONDWIND**

TRITON® SONIC WIND PROFILER SPECIFICATIONS

DATA CAPTURE

Maximum height	200 m
Wind data capture heights	40, 50, 60, 80, 100, 120, 140, 160, 180, 200 m
Wind speed range	0–25 m/s (0–55 mph)
Data recovery rate (unfiltered)	>98% (at all heights)
Filtered data recovery rate*	>95% at 60 m; >90% at 80m (with >90% Quality Factor)
Filtered data correlation	Within 2% of anemometers
Data upload rate	Every 10 minutes, via communications link. Automatic data buffering and backfilling protocol.
SD memory card socket	2 GB SD card records a minimum of 2 years of 10 minute data.

*Filtered data recovery rate represents the percentage of Triton data with a Quality Factor >90% averaged over a 12-month period to account for seasonal and diurnal effects. Application of a minimum QF of 90% removes low quality data associated with atmospheric stability, atmospheric absorption, and precipitation events. The Triton's Filtered Data Recovery Rate is equivalent to "directionally filtered data" from met tower mounted anemometers.

POWER SUPPLY

Power consumption	7 W (average)
Solar panels	2 panels, each rated @ 85 W
Internal batteries	Leak-proof AGM marine batteries, rated 12V, 92 Ah.
Battery capacity	Internal shipping-safe mounting system holds up to 4 batteries, for 20 days of operation without charging. (See note under "Mirror Heater System/Battery Capacity")

INSTALLATION

Footprint	2 m x 3 m (6' x 9') with solar panels fitted
Orientation	Dual-axis accelerometer for automatic correction for out-of-level. Site location determined by GPS.
Leveling of base	Within 3° of level in x and y axes

OPERATION

Ambient temperature	–40°C to +65°C (–40°F to +150°F)
Frequency of sound beams	4,500 Hz (nominal), with automatic temperature correction
Number of sound beams	3
Data sampling rate	~100 'chirps' per sound beam per 10 minute period
Duration of sound 'chirp'	60–100 milliseconds
Sound level at ear level	87 dBA at 0m; 63 dBA at 50m (intermittent sound source)

TRANSPORTATION

Dimensions	2 x 2 x 2 m (6' x 6' x 6'). 1.2m (3' 11") wide base fits pick-up truck bed or trailer
Weight	350 to 450 kg (750 to 1000 lbs.) depending on configuration
Integrated shipping	Triton and all accessories ship as one unit

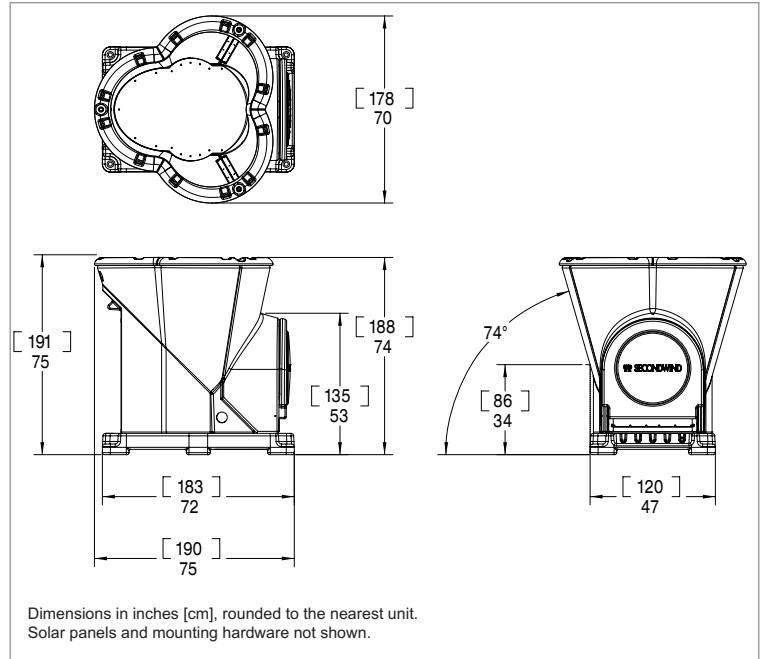

Dimensions in inches [cm], rounded to the nearest unit. Solar panels and mounting hardware not shown.

MIRROR HEATER SYSTEM

Energy source	LPG (propane)
Storage capacity (to be provided by the customer)	Triton enclosure has nesting locations for (1) 18 kg (40 lbs.) and (1) 14 kg (30 lbs.) LPG bottles with a combined capacity of 32 kg (70 lbs.).
Run time	Up to 200 hours of snow melting with 32 kg (70 lbs.) internal propane supply.
Heater control	Intelligent system with satellite control capacity
Battery capacity	For heater-equipped Tritons, frequent heater activations will reduce the time of battery operation without a charging event.

Configurations

STANDARD TRITON

Includes 2 batteries, 2 solar panels, Globalstar modem and antenna, and 4 screw-in ground anchors.

TRITON WITH HEATER PREP

Standard Triton plus 2 additional batteries, heatable mirror, and heater tubing.

TRITON WITH MIRROR HEATER

Above, plus complete mirror heater system.